

usb cnc 6040 3 1500w 200w 3 4 3 4

- 1. 1500w/2 200w 3 4 3 4
- 2. 3 4 3 4 3 4 3 4
- 3. z 105mm 145mm
- 4. usb (usb 3 4 3 4) Mach3 usb
- 5.
- 6.
- 7.
- 8.
- 9. MACH3
- 10. 3 usb cnc
- 11. pcb etc
- 12. 80mm
- 14.
- 15. cnc

usb cnc 6040 3 1500w 200w 3 4 3 4

usb cnc 6040 3 1500w 200w 3 4 3 4

usb cnc 6040 3 1500w 200w 3 4 3 4

usb cnc 6040 3 1500w 200w 3 4 3 4

usb cnc 6040 3 1500w 200w 3 4 3 4

usb cnc 6040 3 1500w 200w 3 4 3 4



## 02 Parameters China zone

□□

Mach3 usb cnc 6040 3 □ 4 □ <a href="#">cnc</a> □□□ □□ □□		
□□□□ □□ □□	580 (x) mm * 400 (y) mm * 105 (z) mm	
□□ □□	880 * 670 * 640mm	
□□ □□ □□ □□	750 50mm * 450mm < 150mm	
□□ □□□ □□	750 mm * 480mm	
□□□ □□	□□□□ □□ 6063 □ 6061 □□□ □ □□□□ □ □□ □ □□□. □□ □ □□□	
□□ □□□ □□ □□	≤ 145	
□□ □□	x □	1605 □ □□□
	y □	1605 □ □□□
	z □	1605 □ □□□
□□□□ □□	x □	□□ 16mm □□ □□□□ □ □
	y □	dia. 20mm □□ □□□□ □ □
	z □	□□ 13mm □□ □□□□ □ □
□□□ □□ □□	57 2-□□ 3a 150N.cm	

最大速度	最大速度 1.5 k w 最大速度 24, 000rpm
主轴规格	ER11/3.175 mm/6mm
主轴精度	0.05 mm
主轴重复定位精度	±0.03 mm
支持的格式	g 代码/nc 代码/dxf 文件/iso 文件
接口	usb 接口
操作系统	windows xp/win7/win10
进给速度	0-4000mm/min
切削速度	0-2500mm/min (取决于材料)
电机	步进电机 + pwm 控制 + TB6560 3 轴驱动板
接口	usb 接口
精度	±0.05 mm
软件	Mach3, 支持 cnc
电压	±0.05 mm
功率	ac110v/ac220v
重量 (不含底座)	3 轴 82 kg, 4 轴 85mm
尺寸	尺寸: 122 * 86 * 83

Model: CNC6040



Shape Dimension

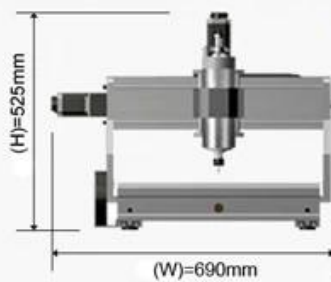
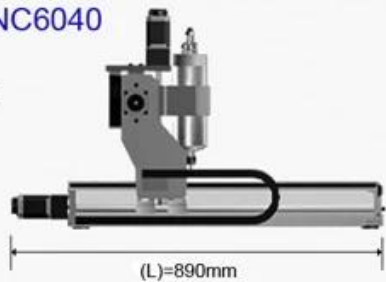

Effective Working Travel

Max. Workpiece Dimension

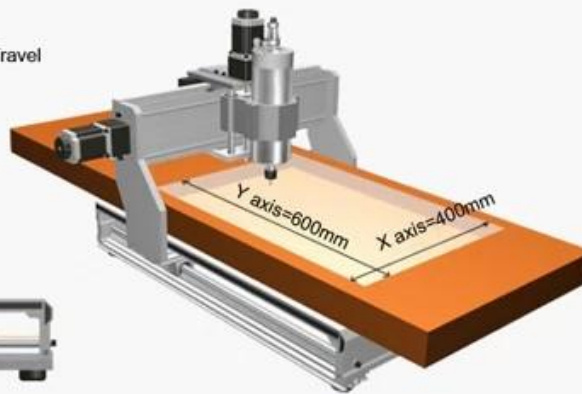
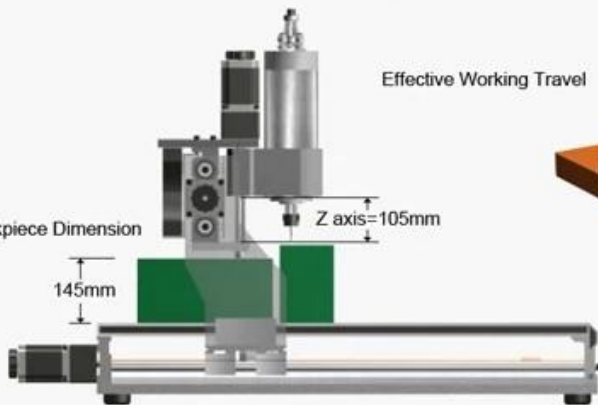













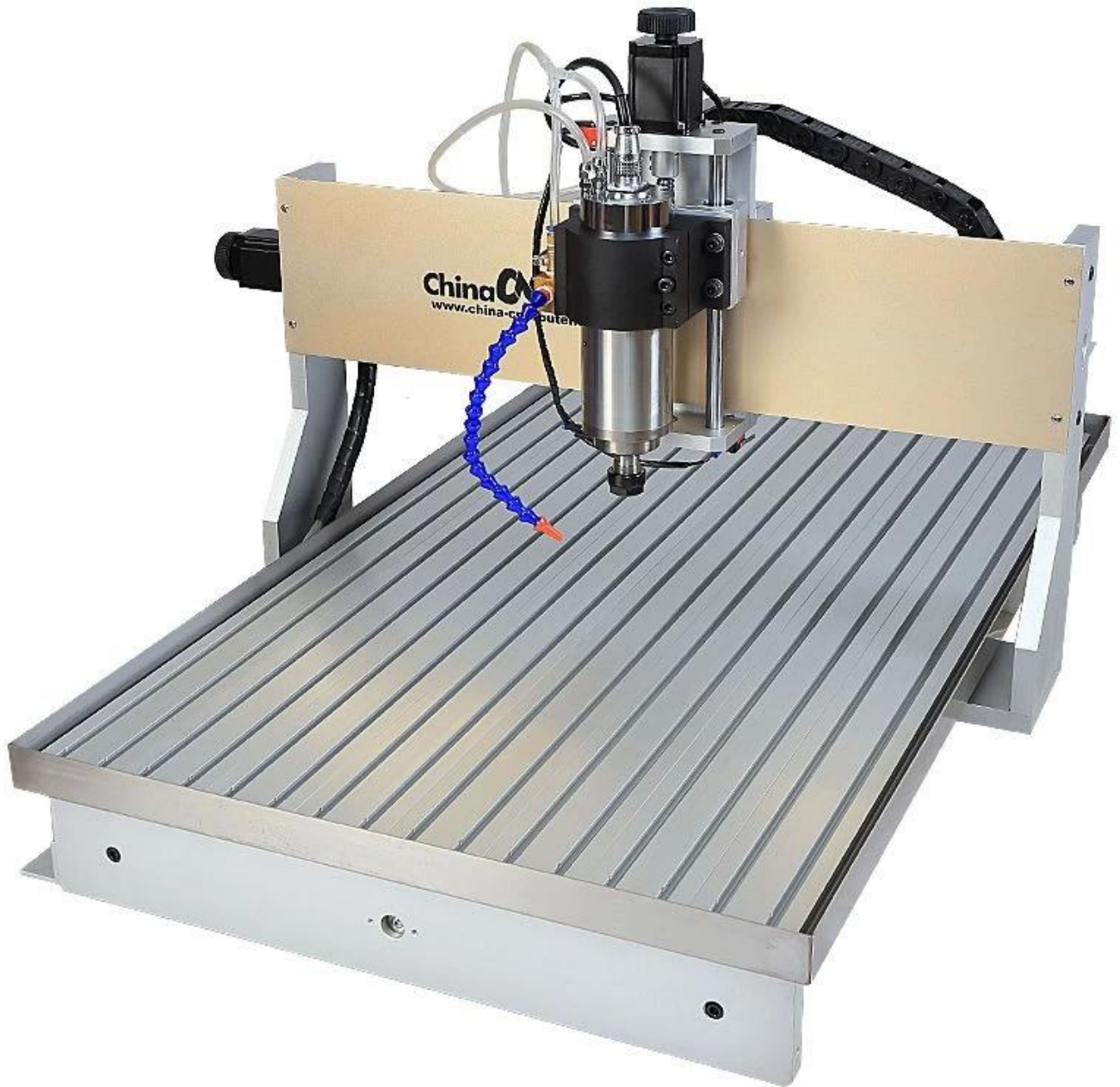





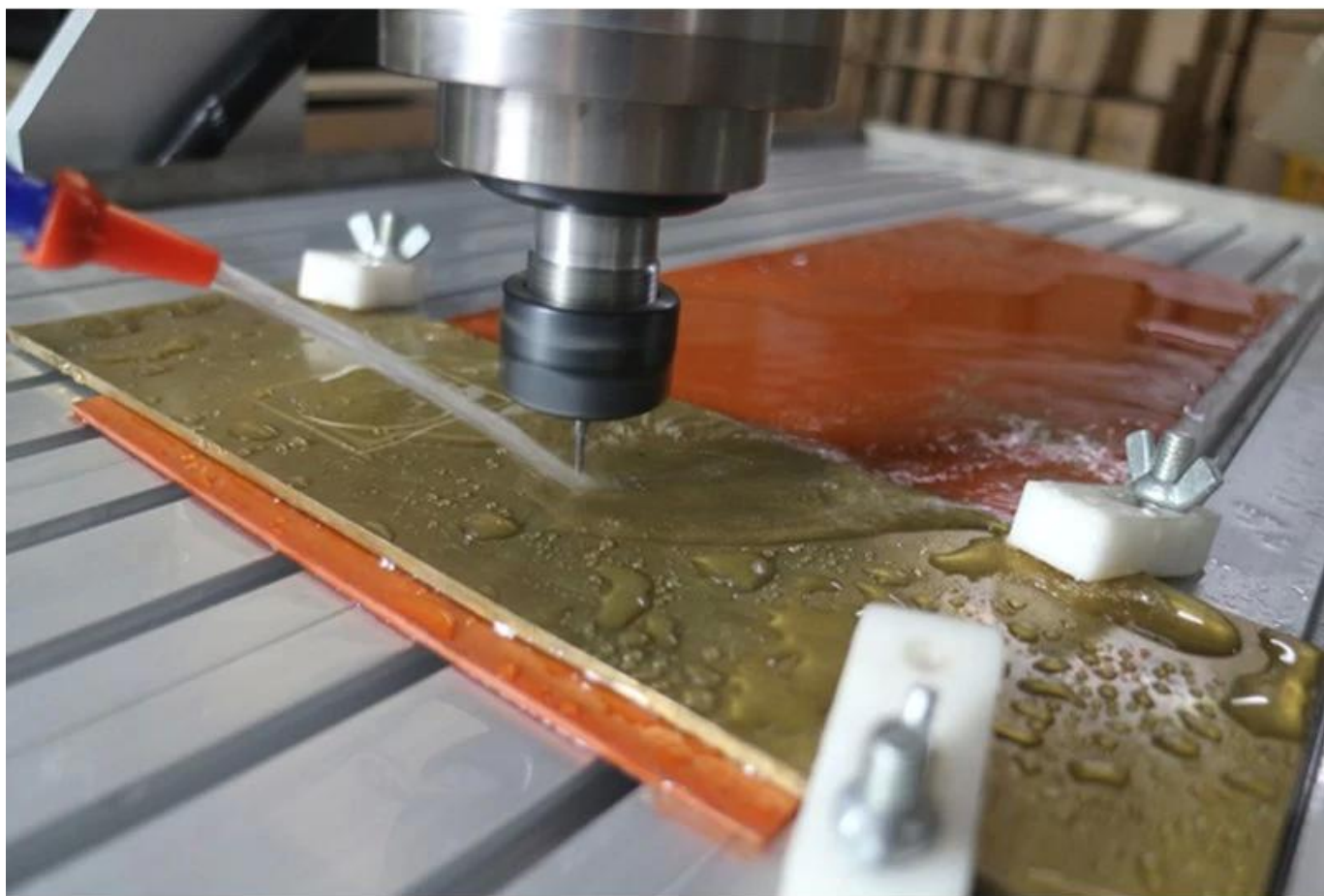



**Ball screw high precision**



**USB Cable**

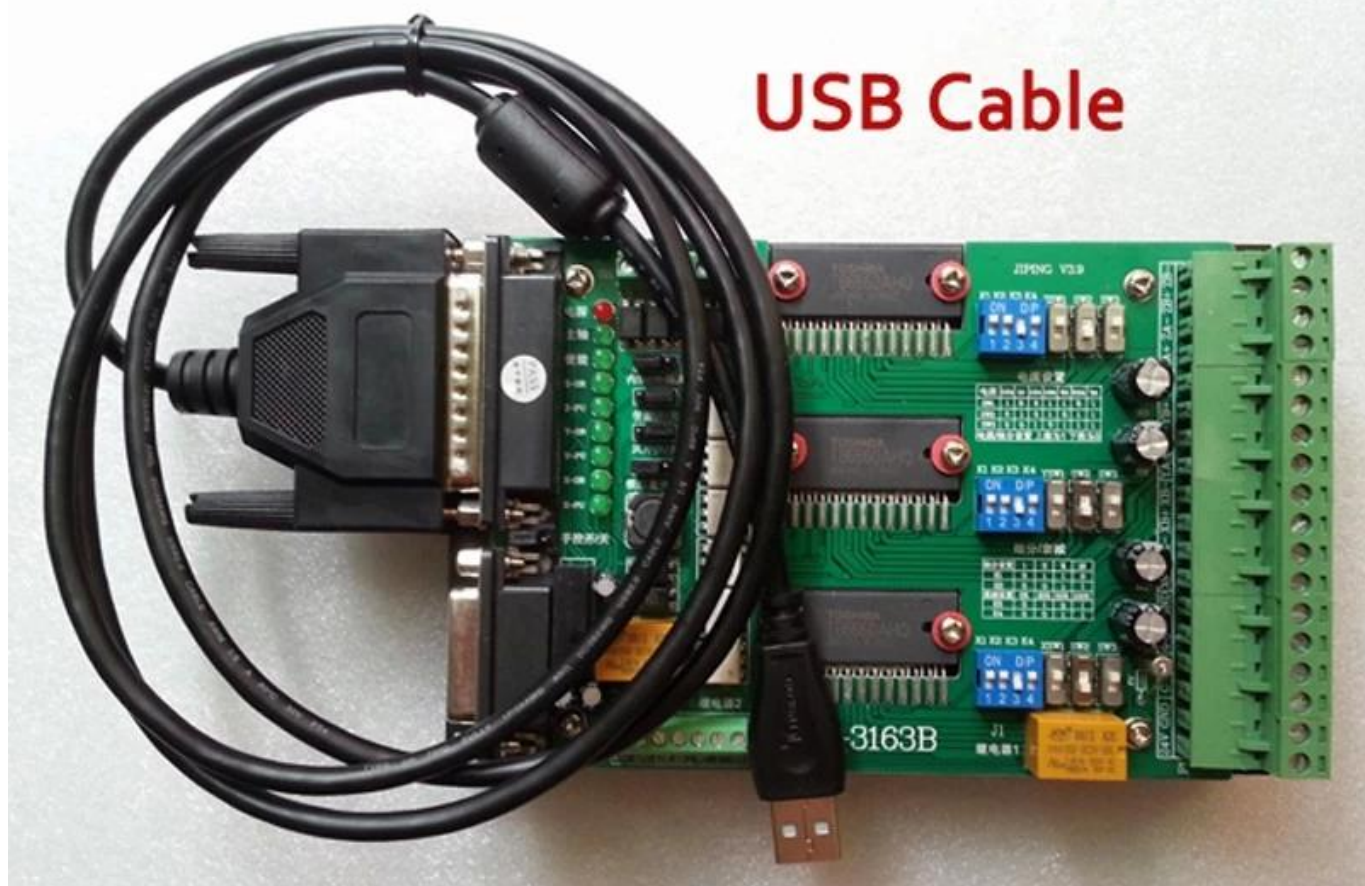



# Type 1 controller

Front



Back



parallel port +

USB CNC cable (option)





# Type 3 controller

Front



Back



+

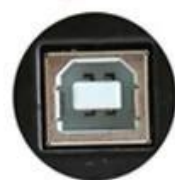

Ethernet USB interface

# New Model

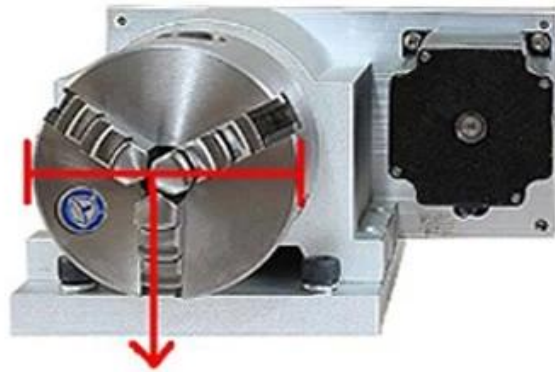

80mm

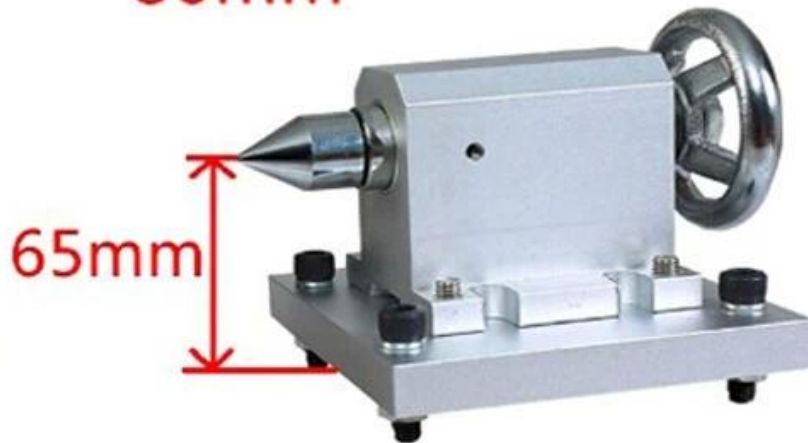

## Rotation Axis

### 04 Applications

China  zone

□ Mach3 usb cnc 6040 3 □ 4 □ □□ cnc □□□ □□ □□ □ □ □□□□ □□□ □□:

□. □□□□ □□ □□□ □□ □□□, □□ □□, □□, pvc, pcb□ □□ □□ □□ □□ etc□.

b. □□, □□, □□□ □ □□□□ □□□□□□.

c. □□□ □□, □□ □□, □□ □□□, □□ □□, □□□, □□ □□□□ □ □□ □□, □□ □□ □□□, □□ □□□, □□, □□□, □□□ □□, rc □□ □□



[www.chinacnczone.com](http://www.chinacnczone.com)

# Live Demo

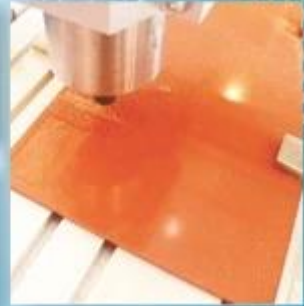

PVC



DOUBLE COLOR BOARDS



WOOD

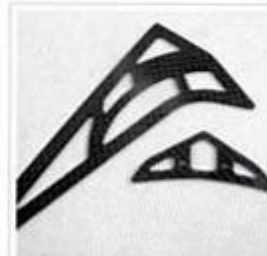

CARBON FIBER REINFORCED PLASTICS PLATE

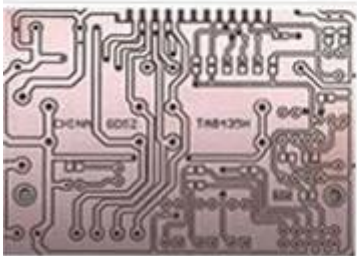

PCB



WAX



DOUBLE COLOR BOARDS



EPOXY TOOLING BOARD









**QA Inspection Area**



**Mechanical Assembly Area**



**Machine Commissioning Area**



**Finish Products Area**



**Packaging Area**





Always be imitated, never be surmounted.

We all use well-designed professional aluminum to manufacture the machine. Almost all of the structural member are extruded by a dedicated mold. The production of large quantities so that we have a strong price competitiveness. Professional mold and materials so that our quality has been stable protection.

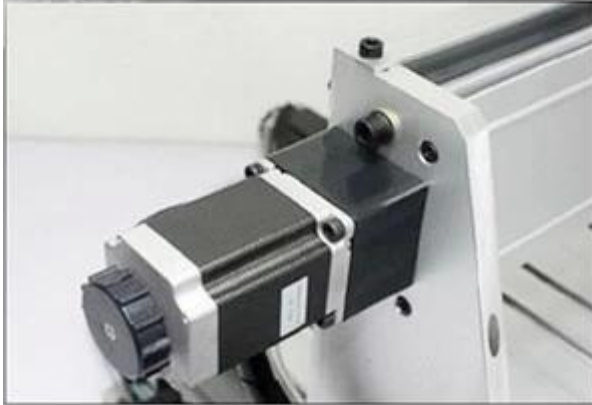





# SHENZHEN SCOTLE TECHNOLOGY GROUP LIMITED

ChinaCNCzone, engrave your colorful life!

## 客户合影及公司文化 Customers and Company Culture

