

Ultime chinacnczone [CNC 6040](#) con sistema di raffreddamento lavello caratteristiche principali come di seguito:

1. 1500W/2200W mandrino raffreddato ad acqua per la selezione
2. ha 3 assi e 4 assi per la vostra selezione, il [3 assi CNC](#) può essere aggiornato in [4 assi](#) facilmente e direttamente dopo aver ottenuto il ChinaCNCzone quarto asse.
3. l'area di lavoro efficace asse z è 105 mm, e accettare materiale di spessore 145mm.
4. ha il regolatore del USB (può essere collegato con il calcolatore dalla porta parallela e dal taccuino dall'interfaccia del USB) e Mach3 il regolatore del USB per la vostra selezione.
5. vite a sfera alta precisione.
6. alimentazione indipendente per la scheda madre, prolungare con la vita.
7. interruttore limitato aggiunto.
8. funzione di controllo automatico.
9. la velocità del mandrino può essere controllata dal software Mach3.
10. software: compatibile con il software di CNC di Mach 3 o del USB.
11. può incidere materiale tale acrilico, ottone, legno, alluminio, PCB ecc.
12. Diametro mandrino: 80mm
14. con sistema acqua-freddo.
15. dalla Cina professionale [mini router CNC](#) Produttore.

Perché aggiungere il sistema di raffreddamento del lavandino?

Può raffreddare il mandrino e proteggere la macchina.

Evitare che il mandrino si bruci. quando si

Può incidere l'alta durezza o metallo

Può migliorare l'efficienza e la precisione della macchina.

Nota: si può anche intrested in seguito, basta cliccare qui sotto link::

Un. [Le caratteristiche eccezionali per ChinaCNCzone Mach 3 USB CNC 6040 3 Axis 1500W 2200W](#)

B. [I confronti di CNC 6040 realizzati da ChinaCNCzone e altri fornitori.](#)

C. [Quali sono le differenze tra ChinaCNCzone nuovo CNC 6040 e vecchia versione?](#)



02 Parameters China zone

□□

Mach3 USB CNC 6040 3 asse 4 assi Mini CNC Parametri router		
Efficace viaggio di lavoro		580 (x) mm * 400 (y) mm * 105 (z) mm
Dimensione forma		880 * 670 * 640mm
Dimensione max. pezzo		750 * 450mm < 150mm
Dimensione tabella di lavoro		750 * 480mm
Materiali della struttura		lega di alluminio 6063 e 6061 la muffa unica e dedicata profili di estrusione. Lasciate che i falsari nani
spessore materiale accettabile		≤ 145
Unità di guida	Asse x	1605 sfere
	Asse y	1605 sfere
	Asse z	1605 sfere
Unità scorrevoli	Asse x	Ø 16mm cromato alberi
	Asse y	Ø 20mm piastra cromata alberi
	Asse z	Ø 13 millimetri piastra cromata alberi
Stepping tipo di motore		57 2-fase 3a 150N.cm

Mandrino motore	nuovissimo mandrino di raffreddamento ad acqua 1.5 kW, 24000rpm
Asse principale coltetto	Er11/3.175 mm/6mm
Precisione di ripetizione	0,05 mm
Precisione mandrino	battito radiale acuità 0,03 mm
Istruzioni carving	G codice/scheda file/file NC/file NCC/file DXF/file Gerber
Interfaccia di comunicazione	tramite connessione parallela e USB con computer
Ambiente software	Windows XP/Win7/Win8/WIN10
Velocità massima	0-4000mm/min
Carving velocità	0-2500mm/min (diversi materiali differiscono)
Unità di controllo	Trasformatore toroidale + modulo di alimentazione PWM + tb6560 3axis scheda di azionamento
Connessione al computer	porta parallela/porta USB
Codice di comando	Codice g
Software accettabile	Mach3, usbcnc
Protezione	Pulsante di arresto di emergenza
Tensione di esercizio	AC110V/AC220V
Peso macchina (peso imballo)	3 assi 82KG, 4 assi 85kg
dimensione del pacchetto	Top: 122 * 86 * 83

Model: CNC6040



Shape Dimension

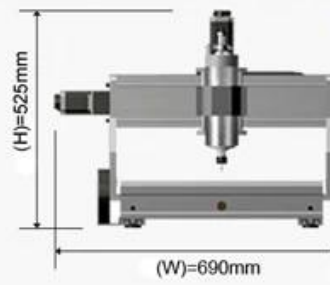
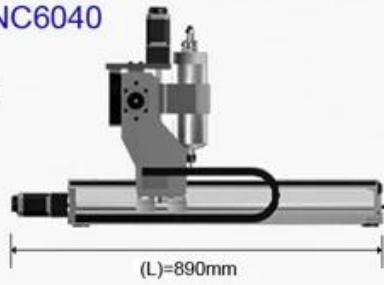

Effective Working Travel

Max. Workpiece Dimension

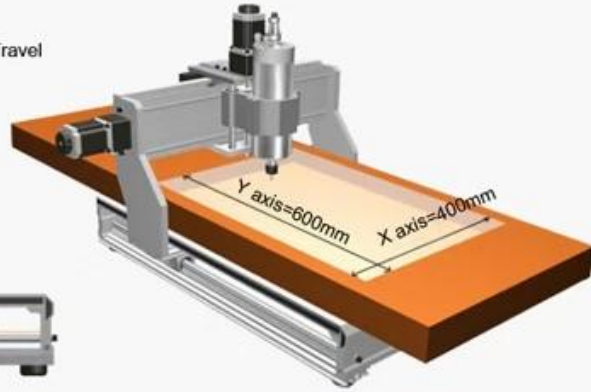
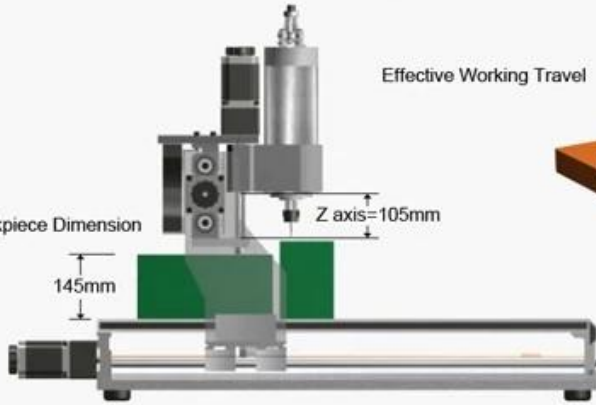









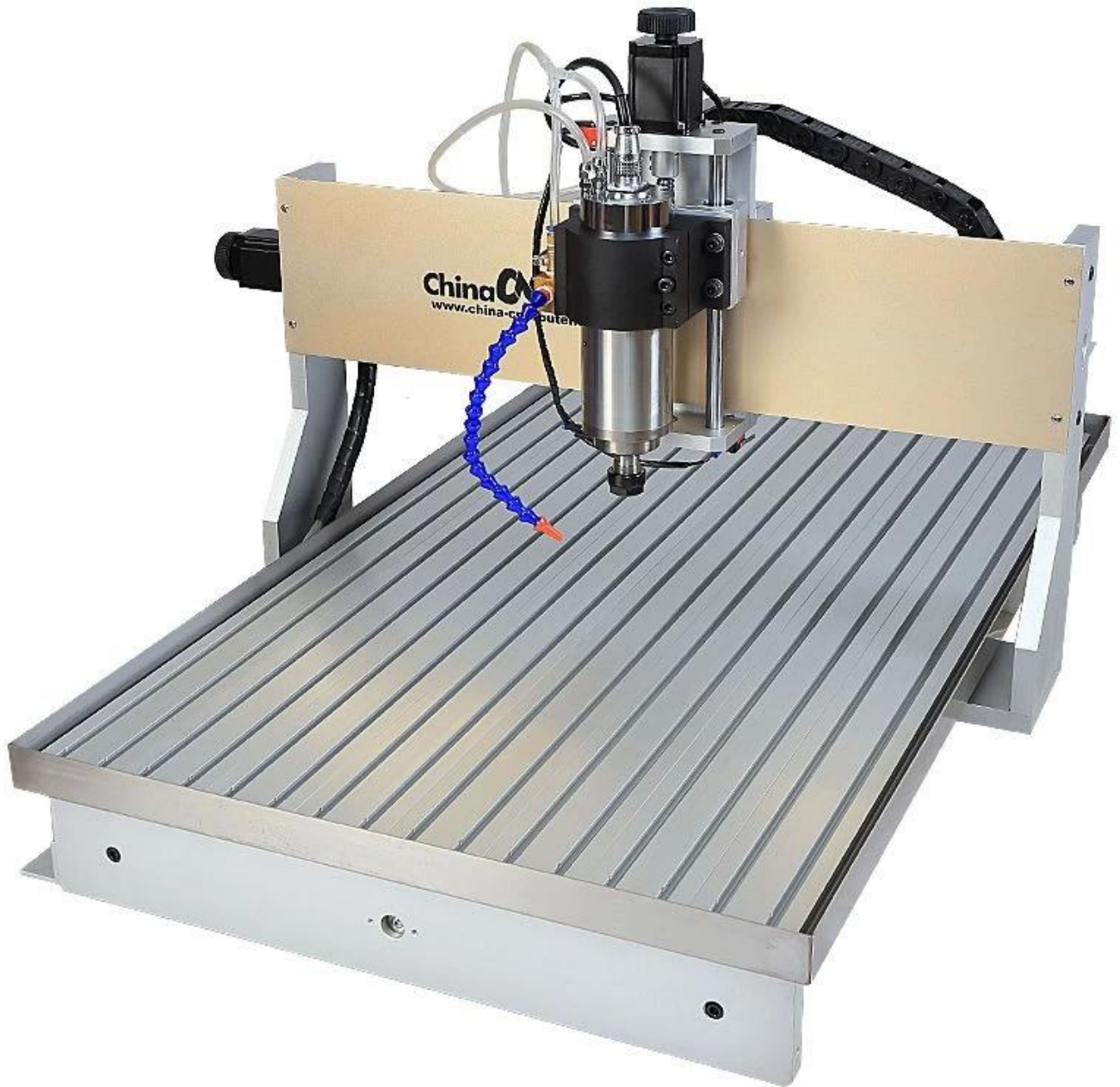



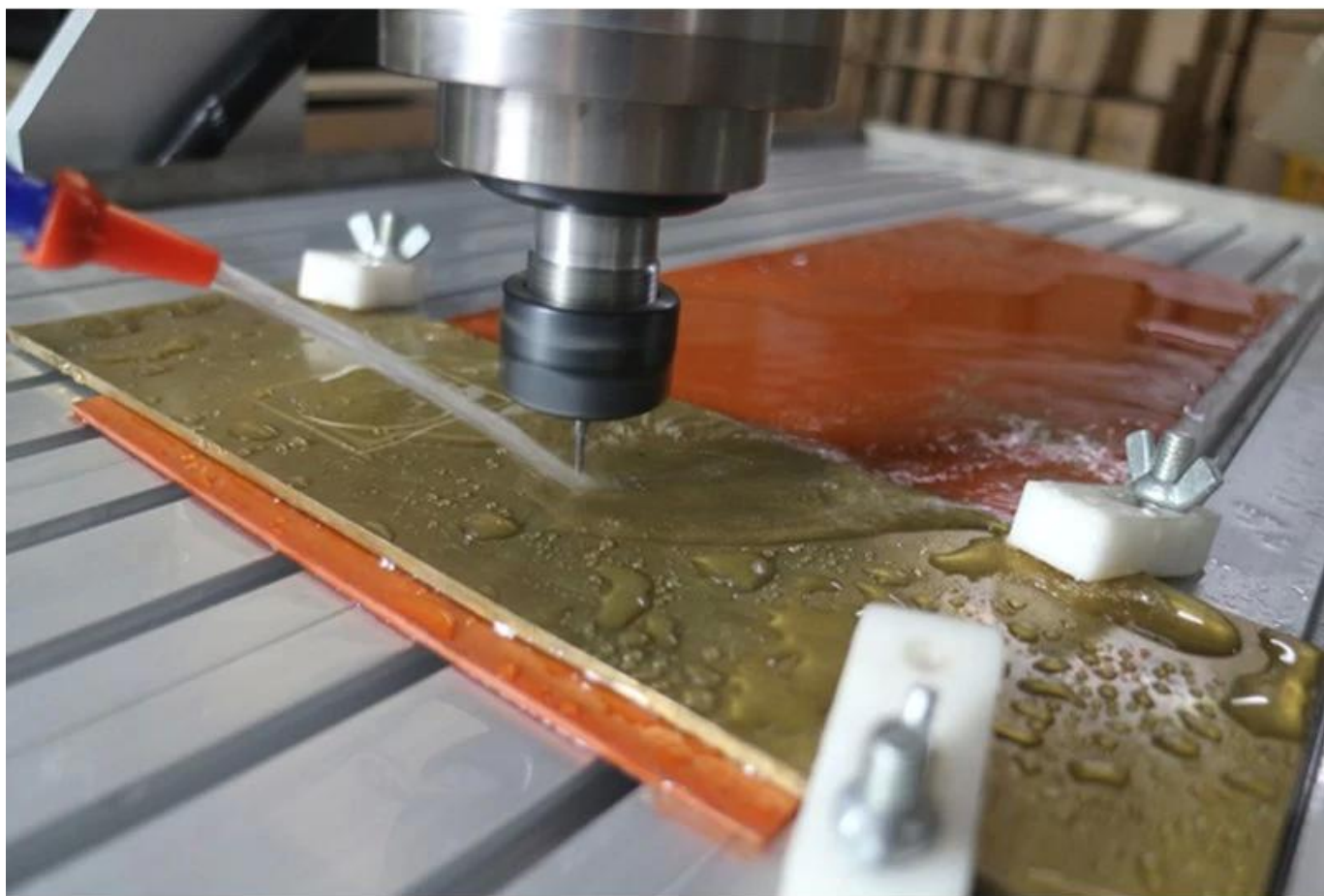



Ball screw high precision



USB Cable

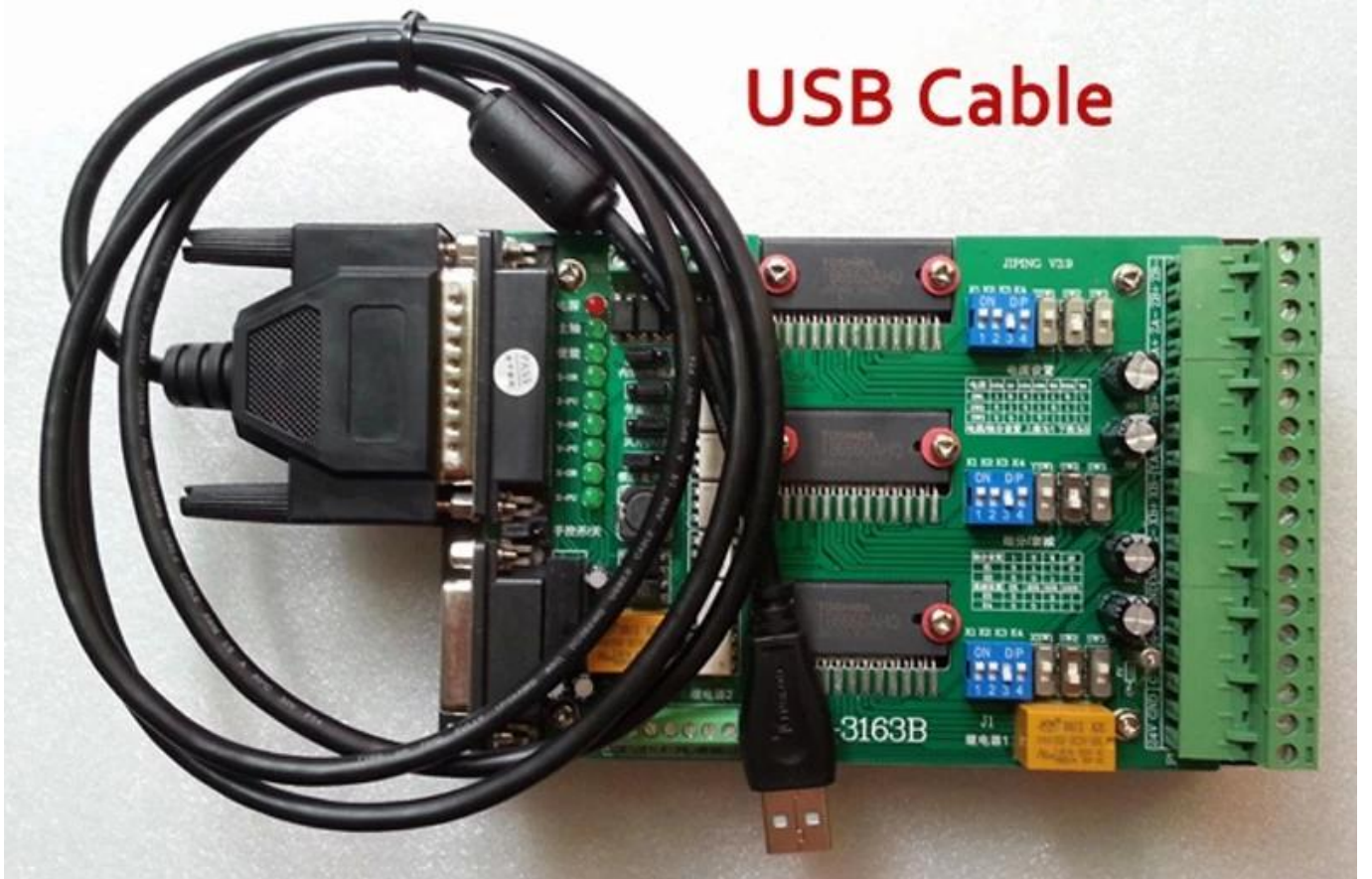

Type 1 controller

Front



Back



parallel port +

USB CNC cable (option)



Type 3 controller

Front



Back



+



Ethernet USB interface

New Model

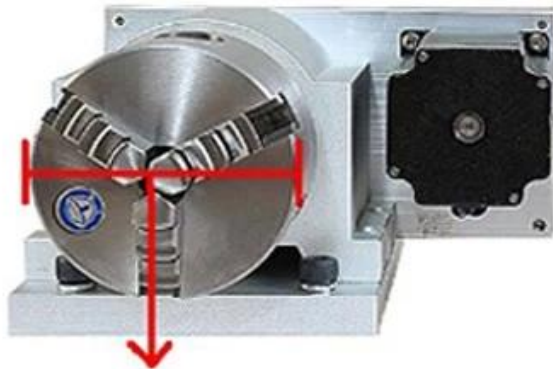

80mm



Rotation Axis

04 Applications

China  zone

Questo Mach3 USB CNC 6040 3 Axis 4 Axis Mini router CNC può essere ampiamente utilizzato come di seguito:

Un. [Ampiamente usato non solo per alluminio ma anche acrilico, ottone, legno, PVC, PWB ecc.](#)

B. ideale per fresatura, incisione, foratura e instradamento.

C. per industria, ricerca di tecnologia, disegno di pubblicità, arti Creazione, insegnamento, progetto studentesco e Hobby, modello edilizio Making, segni pubblicitari, opere d'arte, artigianato, modelli di aeromobili, rc parti di modello



www.chinacnczone.com

Live Demo

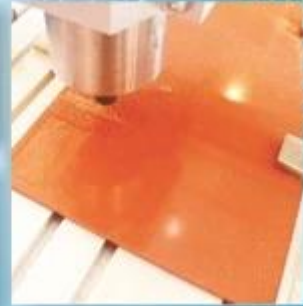

PVC



DOUBLE COLOR BOARDS



WOOD

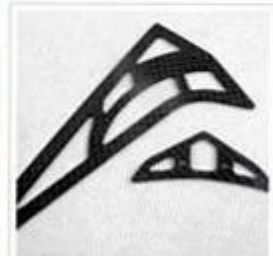

CARBON FIBER REINFORCED PLASTICS PLATE

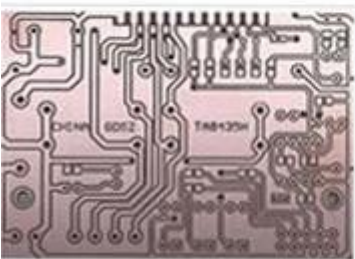

PCB



WAX



DOUBLE COLOR BOARDS



EPOXY TOOLING BOARD







QA Inspection Area



Mechanical Assembly Area



Machine Commissioning Area



Finish Products Area



Packaging Area



Always be imitated, never be surmounted.

We all use well-designed professional aluminum to manufacture the machine. Almost all of the structural member are extruded by a dedicated mold. The production of large quantities so that we have a strong price competitiveness. Professional mold and materials so that our quality has been stable protection.

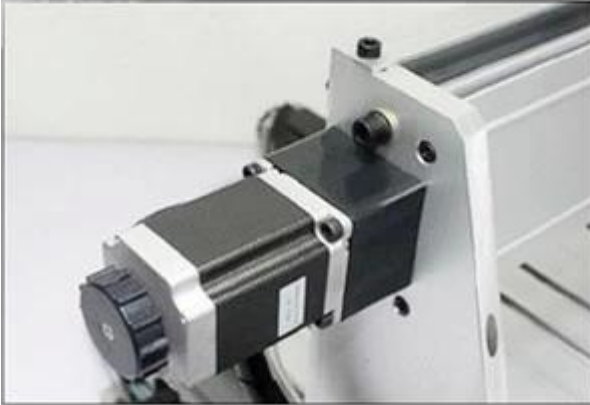



SHENZHEN SCOTLE TECHNOLOGY GROUP LIMITED

ChinaCNCzone, engrave your colorful life!

客户合影及公司文化 Customers and Company Culture

